

MSB1236C

Digital DVB-T/T2 Demodulator

Preliminary Data Sheet Version 0.1

Mstar Confidential
for Honestar Technology
Company Limited
Internal Use Only

Mstar Confidential
for Honestar Technologies
Company Limited
Internal Use Only

© 2012 MStar Semiconductor, Inc. All rights reserved.

MStar Semiconductor makes no representations or warranties including, for example but not limited to, warranties of merchantability, fitness for a particular purpose, infringement of any intellectual property right or the accuracy or completeness of this document, and reserves the right to make changes without further notice to any products herein to improve reliability, function or design. No responsibility is assumed by MStar Semiconductor arising out of the application or user of any product or circuit described herein; neither does it convey any license under its patent rights, nor the rights of others.

MStar is a trademark of MStar Semiconductor, Inc. Other trademarks or names herein are only for identification purposes only and owned by their respective owners.

REVISION HISTORY

| Revision No. | Description | Date |
|--------------|-----------------------------------------------------------------|------------|
| 0.1 | <ul style="list-style-type: none">Initial release | 11/29/2012 |

Mstar Confidential
for Honestar Technologies
Company Limited
Internal Use Only

FEATURES

■ Integrated DVB-T/T2 Receiver

- Compliant with DVB-T (ETSI EN 300 744)
- Compliant with DVB-T2 (ETSI EN 302 755)
- Supports all guard intervals (1/128 to 1/4)
- Supports all FFT modes from 1K to 32K
- Supports all long and short block code rates (1/2, 3/5, 2/3, 3/4, 4/5, 5/6)
- Supports all constellations (QPSK, 16-QAM, 64-QAM, 256-QAM)
- Transmit diversity (MISO) support
- Supports all scattered pilot patterns (PP1 to PP8)
- Supports rotated and non-rotated constellations
- Supports single and multiple PLPs
- Nordig 2.3, D-Book 7.0
- Automatic co-channel and adjacent channel interference suppression
- All digital demodulation and timing recovery loops for tracking frequency and clock offset
- CCI and ACI rejection capability
- Impulse-Noise suppression
- Advanced performance for SFN networks

■ Miscellaneous

- Accept IF, low IF inputs in 1.7, 5, 6, 7, 8MHz channel bandwidths
- Configurable parallel/serial MPEG-2 transport stream interface
- Fast channel acquisition and auto-scan time
- Clock generation from a single crystal
- On chip MCU to reduce host control overhead
- Supports I2C interface with bypass mode
- 48 pin LQFP package

Mstar Confidential
for Honestar Technologies
Company Limited
Internal Use Only

BLOCK DIAGRAM

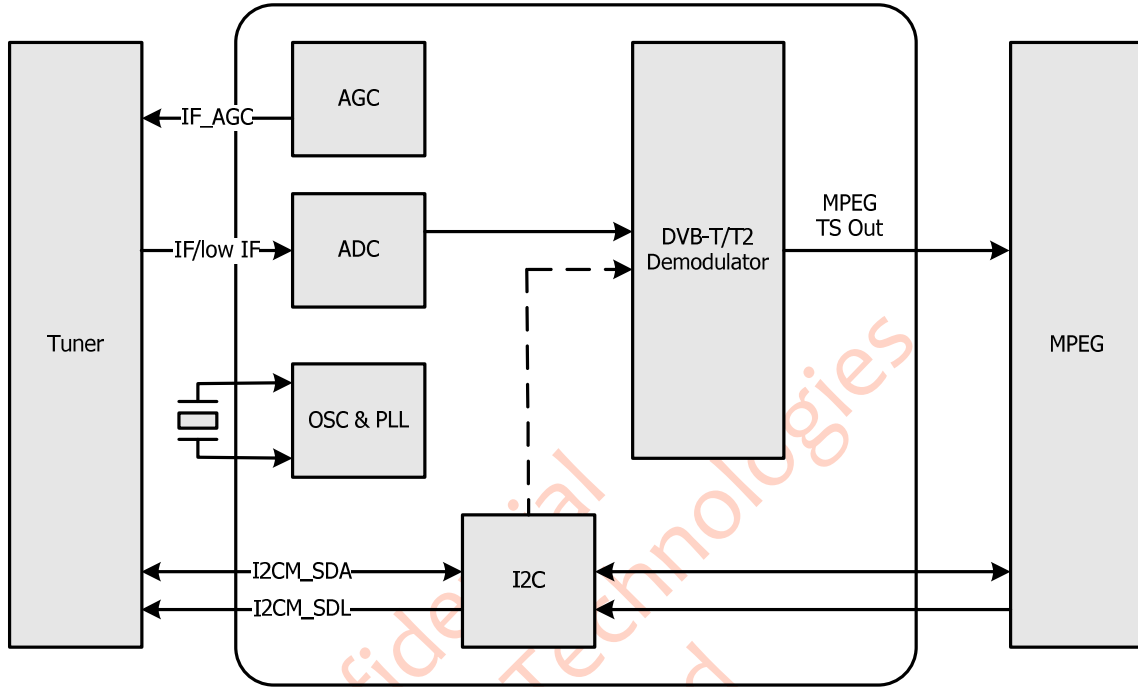

Mstar Confidential
for Honestar Technologies
Company Limited
Internal Use Only

GENERAL DESCRIPTION

The MSB1236C is a single chip demodulator supporting DVB-T2 and DVB-T standards. The MSB1236C enables the design of ETSI EN302755 compliant receivers with performance exceeding DTG Dbook 7.0 requirements. The device integrates a house keeping microcontroller that takes care of all real time and algorithmic tasks simplifying the host control interface.

The MSB1236C front end can accept tuners that provide IF, low IF output. A high rejection channel filter has been included easing the channel filtering requirement of the tuner whilst still meeting the stringent requirements for adjacent channel interference. The MSB1236C may be clocked directly using a crystal, typically 24MHz.

The MSB1236C is capable of blind acquisition of DVB-T and T2 signals. All parameters may be detected in this mode enabling fast and accurate auto scanning. Its frequency recovery circuit is capable of compensating for all typical tuner and broadcast frequency errors.

For DVB-T, a novel impulsive interference filter has been implemented to remove impulsive interference without affecting normal operation thus reducing the effects of transient interference known to affect the quality of OFDM digital TV reception.

Mstar Confidential
for Honestar Technology
Company Limited
Internal Use Only

PIN DIAGRAM (MSB1236C)

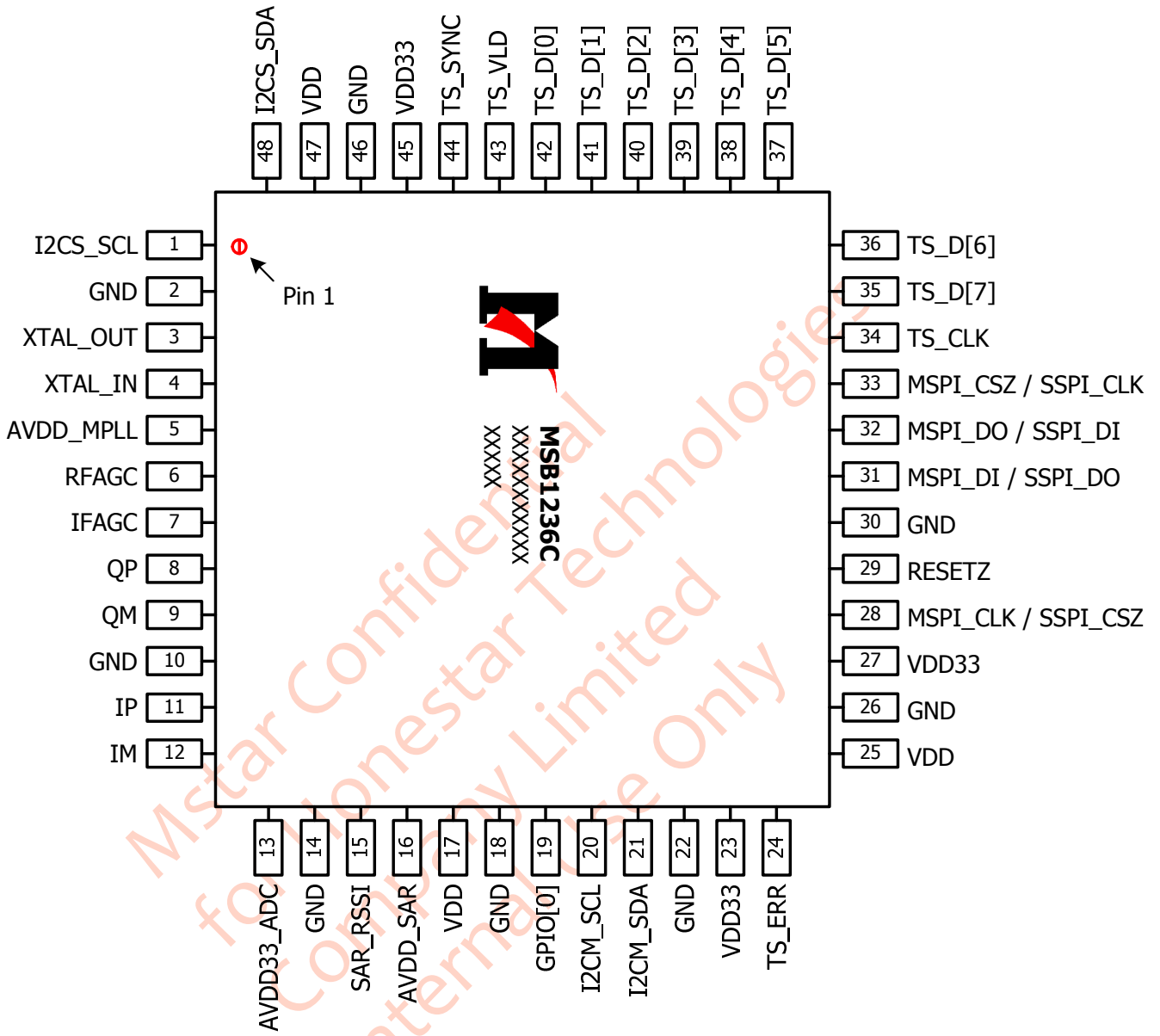

PIN DESCRIPTION

Analog Interface

| Pin Name | Pin Type | Function | Pin |
|----------|---------------------------|---------------------------|-----|
| SAR_RSSI | Analog Input | RSSI Input | 15 |
| QM* | Analog Input | ADC IF Q Negative Input | 9 |
| QP* | Analog Input | ADC IF Q Positive Input | 8 |
| IM | Analog Input | ADC IF I Negative Input | 12 |
| IP | Analog Input | ADC IF I Positive Input | 11 |
| XTAL_OUT | Crystal Oscillator Output | Crystal Oscillator Output | 3 |
| XTAL_IN | Crystal Oscillator Input | Crystal Oscillator Input | 4 |

*QP/QM: MStar demodulator ZIF input interface is not supported by MSB101T, and the two pins must be connected to ground by a 0.1uF capacitor.

I2C Interface

| Pin Name | Pin Type | Function | Pin |
|----------|----------------------|------------------|-----|
| I2CM_SCL | I/O w/5V-tolerant | I2C Master Clock | 20 |
| I2CM_SDA | I/O w/5V-tolerant | I2C Master Data | 21 |
| I2CS_SCL | Input w/ 5V-Tolerant | I2C Slave Clock | 1 |
| I2CS_SDA | I/O w/ 5V-Tolerant | I2C Slave Data | 48 |

Transport Stream Interface

| Pin Name | Pin Type | Function | Pin |
|-----------|----------|-------------------------------|--------------------------------------|
| TS_SYNC | Output | Transport Stream Packet Start | 44 |
| TS_VLD | Output | Transport Stream Data Valid | 43 |
| TS_D[7:0] | Output | Transport Stream Data Output | 35, 36, 37, 38, 39, 40, 41, 42 |
| TS_CLK | Output | Transport Stream Clock Out | 34 |
| TS_ERR | Output | Transport Stream Block Error | 24 |

SPI Control Interface

| Pin Name | Pin Type | Function | Pin |
|-----------------------|----------|------------------------------|-----|
| MSPI_CSZ/ SSPI_CLK | Output | SPI Flash Chip Select | 33 |
| | Input | SPI Clock Input | |
| MSPI_DO/ SSPI_DI | Input | SPI Flash Serial Data Output | 32 |
| | | SPI Data Input | |
| MSPI_DI/ SSPI_DO | Output | SPI Flash Serial Data Input | 31 |
| | | SPI Data Output | |
| MSPI_CLK/ SSPI_CSZ | Output | SPI Flash Serial Clock | 28 |
| | Input | SPI Chip Select Input | |

Misc. Interface

| Pin Name | Pin Type | Function | Pin |
|----------|--------------------|------------------------------|-----|
| GPIO[0] | I/O w/ 5V-tolerant | General Purpose Input/Output | 19 |
| RESETZ | Input | Chip Reset Input; active low | 29 |
| RFAGC | I/O w/ 5V-tolerant | General Purpose Input/Output | 6 |
| IFAGC | Output | IF Auto Gain Control | 7 |

Power Pins

| Pin Name | Pin Type | Function | Pin |
|----------|------------|----------------------------|-------------------------------------|
| VDD | 1.2V Power | Digital Core Power | 17, 25, 47 |
| VDD33 | 3.3V Power | Digital Input/Output Power | 23, 27, 45 |
| AVDD33 | 3.3V Power | Analog Power | 5, 13, 16 |
| GND | Ground | Ground | 2, 10, 14, 18, 22, 26, 30, 46 |

ELECTRICAL SPECIFICATIONS

Analog Interface Characteristics

| Parameter | Min | Typ | Max | Units |
|-------------------------------------------------------------------------|--------------------------|-----|---------------------|------------------|
| Demod ADC INPUT | | | | |
| Input Signal Full Scale Range (AC-coupled Differential peak-to-peak) | | 1 | | V _{dpp} |
| SAR ADC Input | 0 | | V _{VDD_33} | V |
| DIGITAL INPUTS | | | | |
| Input Voltage, High (V _{IH}) | 2.5 | | | V |
| Input Voltage, Low (V _{IL}) | | | 0.8 | V |
| Input Current, High (I _{IH}) | | | -1.0 | uA |
| Input Current, Low (I _{IL}) | | | 1.0 | uA |
| Input Capacitance | | 5 | | pF |
| DIGITAL OUTPUTS | | | | |
| Output Voltage, High (V _{OH}) | V _{VDD_33} -0.1 | | | V |
| Output Voltage, Low (V _{OL}) | | | 0.1 | V |

Note: Specifications subject to change without notice.

Recommended Operating Conditions

| Parameter | Symbol | Min | Typ | Max | Units |
|-------------------------------|---------------------|------|-----|------|-------|
| 3.3V Supply Voltages | V _{VDD_33} | 3.14 | 3.3 | 3.46 | V |
| 1.2V Supply Voltages | V _{VDD_12} | 1.14 | 1.2 | 1.26 | V |
| Ambient Operating Temperature | T _A | 0 | | 70 | °C |
| Junction Temperature | T _J | | | 125 | °C |

Absolute Maximum Ratings

| Parameter | Symbol | Min | Max | Units |
|----------------------------------------|----------------------|-----|---------------------|-------|
| 3.3V Supply Voltages | V _{VDD_33} | | 3.6 | V |
| 1.2V Supply Voltages | V _{VDD_12} | | 1.32 | V |
| Input Voltage (5V tolerant inputs) | V _{IN5Vtol} | | 5.0 | V |
| Input Voltage (non 5V tolerant inputs) | V _{IN} | | V _{VDD_33} | V |
| Storage Temperature | T _{STG} | -40 | 150 | °C |

Note: Stresses above those listed in Absolute Maximum Ratings may cause permanent damage to the device. This is a stress rating only and does not imply functional operation of the device. Exposure to absolute maximum ratings for extended periods may affect device reliability.

ORDERING GUIDE

| Part Number | Temperature Range | Package Description | Package Option |
|-------------|-------------------|---------------------|----------------|
| MSB1236C | 0°C to +70°C | LQFP | 48-pin |

MARKING INFORMATION

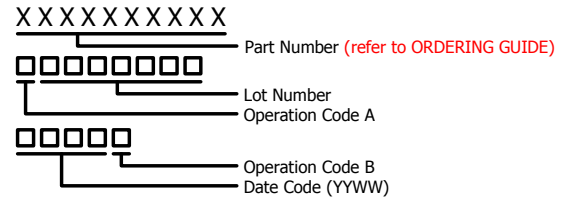

DISCLAIMER

MSTAR SEMICONDUCTOR RESERVES THE RIGHT TO MAKE CHANGES WITHOUT FURTHER NOTICE TO ANY PRODUCTS HEREIN TO IMPROVE RELIABILITY, FUNCTION OR DESIGN. NO RESPONSIBILITY IS ASSUMED BY MSTAR SEMICONDUCTOR ARISING OUT OF THE APPLICATION OR USER OF ANY PRODUCT OR CIRCUIT DESCRIBED HEREIN; NEITHER DOES IT CONVEY ANY LICENSE UNDER ITS PATENT RIGHTS, NOR THE RIGHTS OF OTHERS.



Electrostatic charges accumulate on both test equipment and human body and can discharge without detection. MSB1236C comes with ESD protection circuitry; however, the device may be permanently damaged when subjected to high energy discharges. The device should be handled with proper ESD precautions to prevent malfunction and performance degradation.

Mstar Confidential
for Honestar Technology
Company Limited
Internal Use Only

MECHANICAL DIMENSIONS

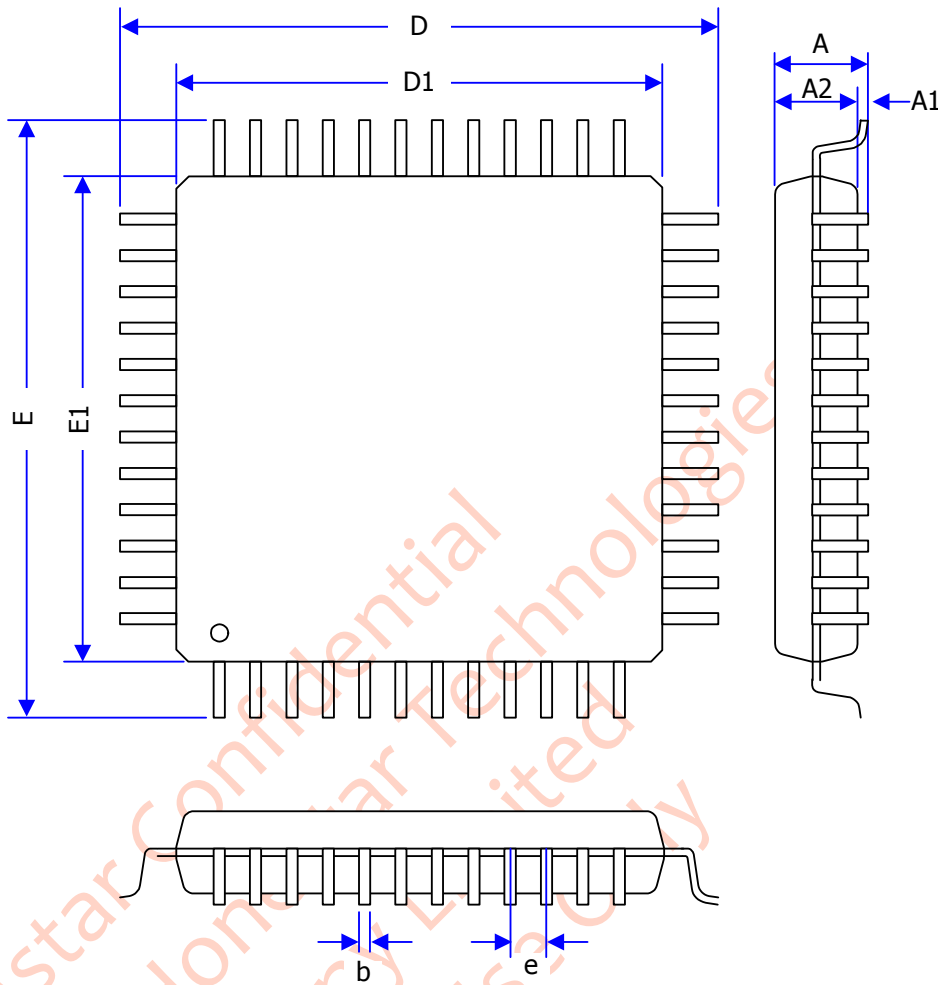

| Symbol | Millimeter | | | Inch | | |
|--------|------------|------|------|-------|-------|-------|
| | Min. | Nom. | Max. | Min. | Nom. | Max. |
| A | - | - | 1.6 | - | - | 0.063 |
| A1 | 0.05 | - | 0.15 | 0.002 | - | 0.006 |
| A2 | 1.35 | 1.4 | 1.45 | 0.053 | 0.055 | 0.057 |
| D | 8.8 | 9 | 9.2 | 0.346 | 0.354 | 0.362 |
| D1 | 6.8 | 7 | 7.2 | 0.268 | 0.276 | 0.283 |
| E | 8.8 | 9 | 9.2 | 0.346 | 0.354 | 0.362 |
| E1 | 6.8 | 7 | 7.2 | 0.268 | 0.276 | 0.283 |
| b | 0.17 | 0.2 | 0.27 | 0.007 | 0.008 | 0.011 |
| e | 0.42 | 0.5 | 0.58 | 0.017 | 0.020 | 0.023 |